

112 Series - Low Coil Power Industrial 2 Amp - SPDT, DPDT



File 252808

The **112 Series** relays are capable of sensing extremely low current flow. They are frequently used to detect ground faults or in applications where applied voltage varies significantly.

DC versions can sense currents as low as 0.61mA and tolerate voltages up to 10X minimum. Single Pole DC Coil versions use as little as 12mW of power while Double pole versions as low as 60mW.

AC versions can sense current as low as 0.74mA and can tolerate voltages up to 5X minimum. Single Pole AC coil versions use as little as 160mVA of power while Double Pole versions can be as low as 800mVA.

User Adjustments: Pickup or Drop-out current can be fine tuned by end user using the knurled thumbwheel after loosening locknut. Retighten locknut when setting is achieved. **Warning:** Be sure to remove power before making adjustments.

PGF covered versions are socket compatible and allow the user to easily remove the cover to make fine adjustments as well.

General Specifications (@ 25°C)



Contacts :

Contact Rating	2 Amp
120 / 240VAC Resistive	2 Amp
28 VDC Resistive	2 Amp
Contact Material -	Fine Silver
Contact Configurations:	XAX (SPDT), AXX (SPST-NO) XBX (DPDT), BXX (DPST-NO) AXA (SPST-NO + SPST-NC)
Contact Resistance, Initial	100 Milliohms max @ 6VDC

Coil:

Coils Available	VAC and VDC, Current Sensitive
Minimum Coil Power:	
Single Pole	160mVA 10mW
Double Pole	800mVA 60mW
Duty	Continuous

Timing:

Operate Time (max)	20mS
Release Time (max)	20mS

Dielectric Strength:

Across Open Contacts	500Vrms
Between Mutually Insulated Points	1500Vrms
Insulation Resistance	1000 Mohms min @ 500VDC

Temperature:

Operating	-20 to 60° C (-4 to 140° F)
Storage	-40 to 105° C (-40 to 221° F)

Life Expectancy:

Electrical (full load operations)	100,000
Mechanical (no load operations)	500,000

Miscellaneous:

Mounting Position -	Any
Mating Socket (P or PGF Versions)	27390 or 27390D (Din Mount) Purchased Separately
Enclosure (P or PGF Versions)	Clear Polycarbonate
Weight	Approx. 6.9 to 7.9 oz (196 - 224 grams)

PGF / P
Version

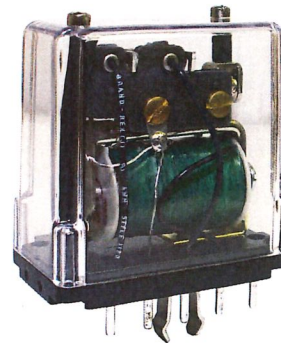

Panel Mount
(Top View)

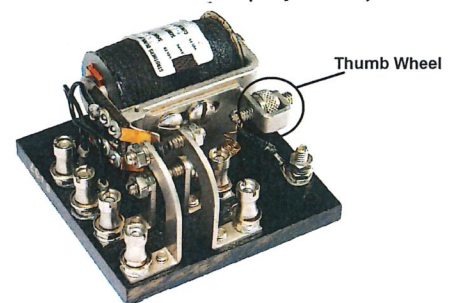

(Photo representations of relays construction may not represent actual construction of relay.)

112 Series - Low Coil Power Industrial 2 Amp - SPDT, DPDT

Panel Mount (XBX)
(Top View)

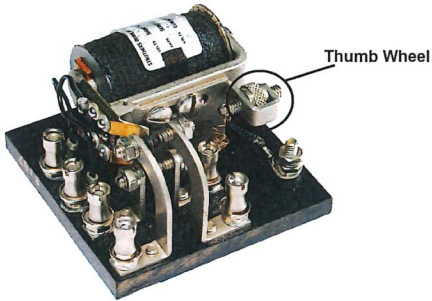

Thumb Wheel

Panel Mount (No Cover) Version

(Photo representations of relays construction may not represent actual construction of relay.)

Ordering Codes

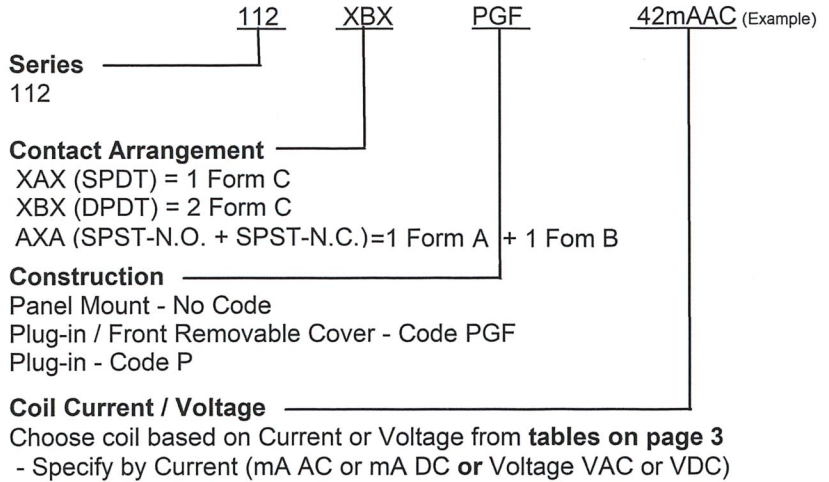

Note: Some older versions available in stock or in use may have a prefix "A" next to the Series Number - A112. This code has no meaning for the relay design or function and is only an historical reference when used.

Wire Diagram

More details on page 4

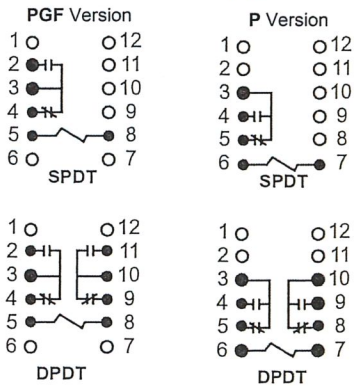

Panel Mount (No Cover) Versions

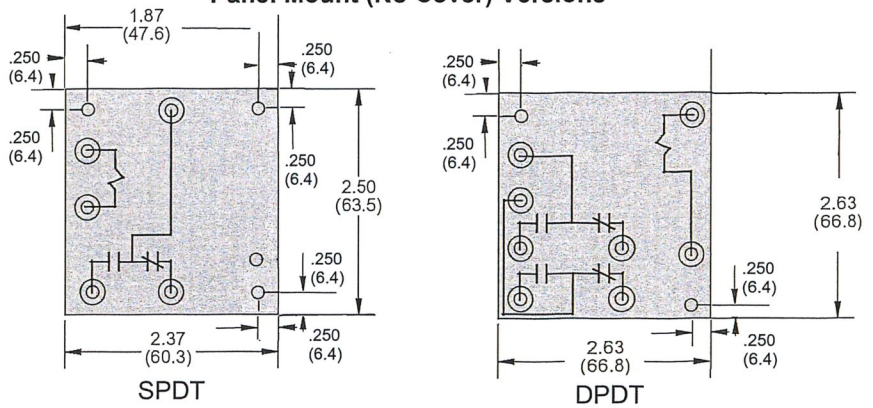

112-PGF Relays have a front removable cover that permits access to the user adjustable "fine tuning" for the Pick-up and Dropout while the relay is plugged in the socket.

112-P are User Adjustable relays but must be separated from the socket to removed the cover screws.

Caution: Disconnect power while making adjustments.

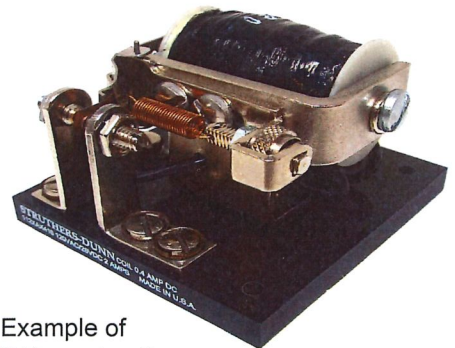
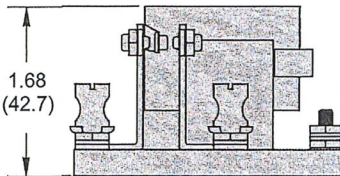

Example of 112XAX construction

Maximum AC Coil Voltage 5X Minimum
 Maximum DC Coil Voltage 10X Minimum
 Neither to exceed 300 volts

CAUTION: DISCONNECT POWER WHILE MAKING ADJUSTMENTS

www.struthers-dunn.com (843)346-4427

April 2022

112 Series - Low Coil Power Industrial 2 Amp - SPDT, DPDT

112XAX (SPDT) Coils

AC Coils (50/60HZ)			DC Coils		
Minimum milliamps	Minimum voltage	Impedance ohms	Minimum milliamps	Minimum voltage	Resistance $\pm 7.5\%$
177.0	1.0	6.0	145.0	0.08	0.55
143.0	1.4	9.0	117.0	0.10	0.84
116.0	1.6	13.0	95.0	0.12	1.26
91.0	2.0	22.0	73.0	0.15	2.10
74.0	2.5	34.0	60.0	0.19	3.10
52.5	3.5	65.0	43.0	0.25	5.80
41.5	4.3	100.0	33.0	0.30	9.0
38.0	5.0	130.0	31.0	0.39	12.50
31.5	6.0	190.0	26.0	0.49	19.0
23.0	8.5	370.0	18.8	0.62	33.0
19.0	12.0	630.0	15.5	0.78	50.0
15.7	13.5	860.0	12.8	0.95	74.0
11.8	16.0	1350.0	9.7	1.30	129.0
9.7	20.0	2070.0	7.9	1.60	197.0
7.7	23.0	3000.0	6.3	2.0	312.0
6.0	33.0	5500.0	4.9	2.50	504.0
4.7	43.0	9230.0	3.8	3.20	840.0
3.9	55.0	14300.0	3.2	3.90	1220.0
3.0	67.0	22500.0	2.4	4.80	1990.0
2.3	87.0	38500.0	1.8	6.40	3450.0
1.9	103.0	53000.0	1.6	8.00	5050.0
1.5	130.0	85000.0	1.3	9.70	7700.0
1.2	146.0	120600.0	1.0	11.70	11700.0
0.95	168.0	177000.0	0.84	16.00	19000.0
0.74	225.0	300000.0	0.61	21.00	34000.0

112XBX (DPDT) Coils

AC Coils (50/60HZ)			DC Coils		
Minimum milliamps	Minimum voltage	Impedance ohms	Minimum milliamps	Minimum voltage	Resistance $\pm 7.5\%$
390.0	2.3	6.0	323.0	0.18	0.55
310.0	2.8	9.0	260.0	0.22	0.84
250.0	3.3	13.0	211.0	0.27	1.26
200.0	4.4	22.0	165.0	0.37	2.10
160.0	5.5	34.0	133.0	0.41	3.10
114.0	6.9	65.0	95.0	0.55	5.80
91.0	9.1	100.0	76.0	0.68	9.0
83.0	10.8	130.0	69.0	0.86	12.50
69.0	13.1	190.0	57.0	1.09	19.0
50.0	20.6	370.0	42.0	1.37	33.0
42.0	26.5	630.0	35.0	1.72	50.0
35.0	30.0	860.0	29.0	2.11	74.0
26.0	35.0	1350.0	22.0	2.77	129.0
22.0	45.5	2070.0	18.0	3.46	197.0
16.4	49.0	3000.0	14.0	4.33	312.0
13.0	72.0	5500.0	11.0	5.47	504.0
10.2	95.0	9230.0	8.5	7.11	840.0
8.5	122.0	14300.0	7.0	8.53	1220.0
6.5	146.0	22500.0	5.5	10.80	1990.0
4.9	190.0	38500.0	4.0	14.10	3450.0
4.3	230.0	53000.0	3.5	17.70	5050.0

112 Series - Low Coil Power Industrial 2 Amp - SPDT, DPDT

WIRING DIAGRAMS

112AXAP
(SPDT-N.O.+N.C.)

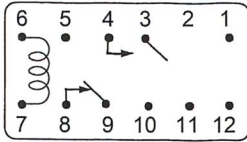

TOP VIEW

112XBX
(DPDT)

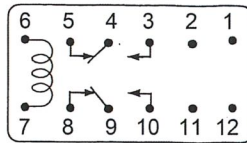

TOP VIEW

Use P or PFG Versions
with Socket 27390 or
27390D (DIN Rail Mountable)
Purchased Separately

112XAX PFG
(SPDT)

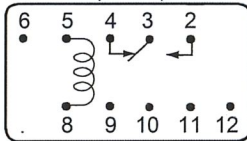

TOP VIEW

112XBX PFG
(DPDT)

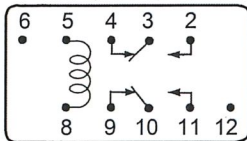

TOP VIEW

112-PGF Relays have front
removable covers. When
cover is removed the relay
can be adjusted without being
plugged in.

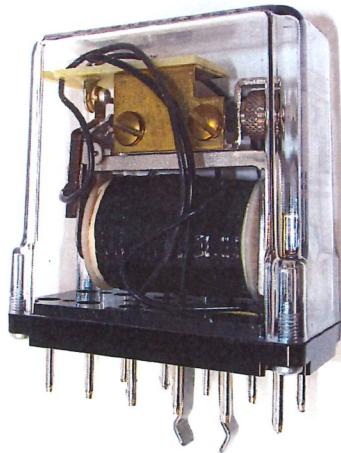

112AXAPGF (Style)

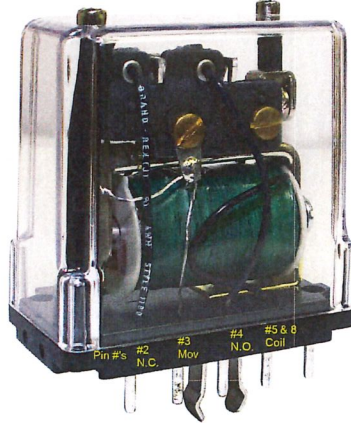

(Photo representations of relays construction may not represent actual construction of relay.)

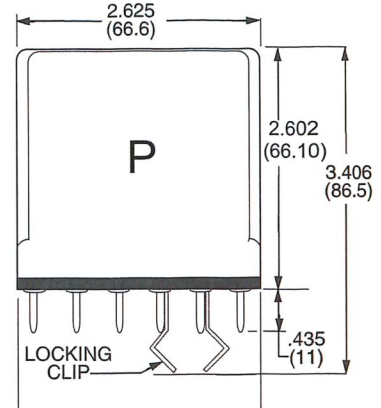

TOP VIEW

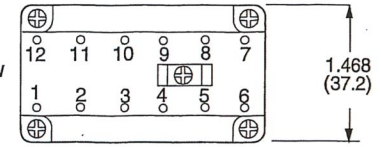

0.10 Dia. x .435 (2.54 x 11)
Typical of all Pin Dimensions

NOTE: Outline Dimensions shown are in
Inches and (Millimeters) and are
Maximum Reference sizes.

Removable cover with top screw for
field adjustment of pull-in.

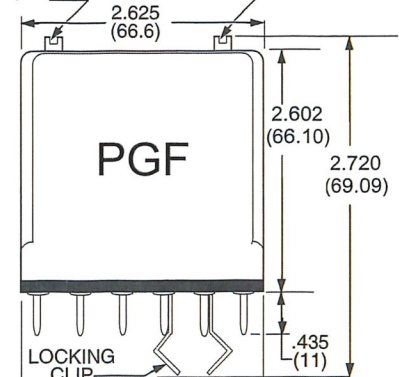

TOP VIEW

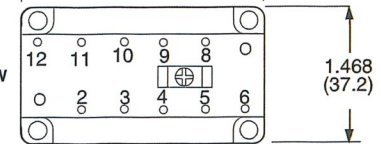

0.10 Dia. x .435 (2.54 x 11)
Typical of all Pin Dimensions